

SEZ. A-A

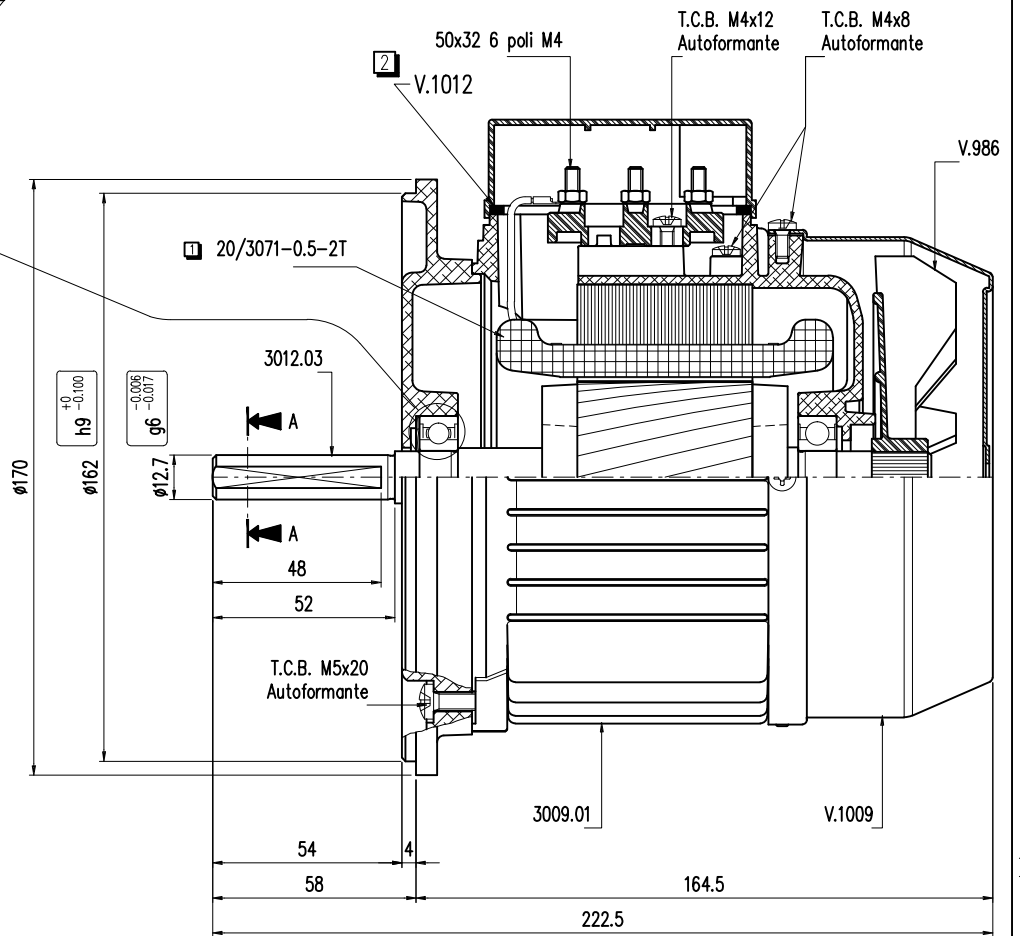
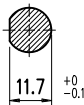

Alimentazione	Colleg.	Tensione	Hertz	Ampere	1/min.	Poli	Watt	Isol.cl.	Protettore termico
TRIFASE	△ /	220	50/60	1.7	2840/3340	2	370	F	.
		380		1		44	S 1	.	Nero
Note	2								

3	aggiunto 60 Hz e 3340 1/min	RMT.UL.08/13	Cassetti	28.11.13
2	era IP40; era TCB m4x12; aggiunto tenuta V.1012	RMT.27/2010	Cassetti	04.05.10
1	Messo avvolgimento in classe "F" era in classe "B"	.	Fabbrì	26.11.96
Rev.	Descrizione revisione	Riferimento	Disegnato	Controllato
		Denominazione	N° Disegno	
		Disegno complessivo	3012.00	
Data 26.10.93		Materiale	Codice	
		Disegnato	1520317032001	
Verifica dei requisiti tecnici N°		Controllato	Codice CAD	
		Fabbrì	1520317032001	
Scala	N° Pezzi	Sost. il:	Sost. dat:	
1:1	1	.	.	